

Block Paving (Non Parking)

Scale 1:10

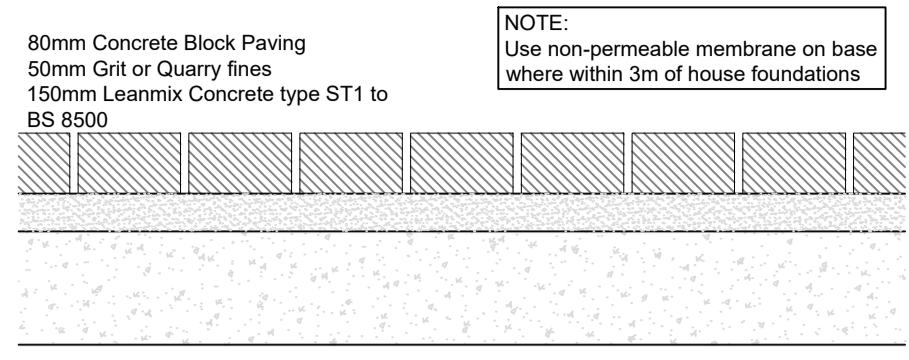

Block Paving (Parking)

Scale 1:10

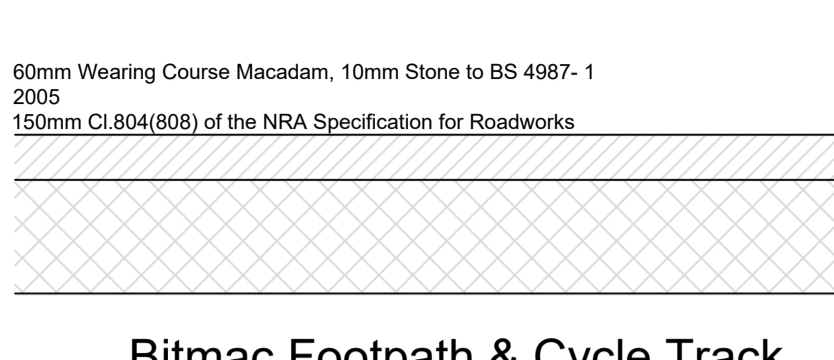

Bitmac Footpath & Cycle Track

Scale 1:10

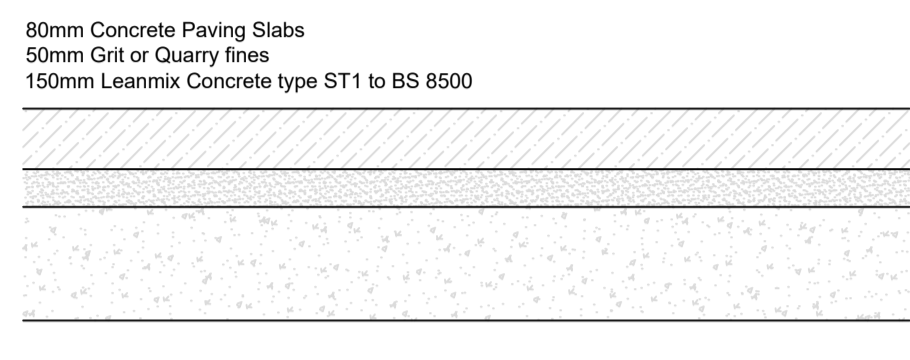

Paving Slab (Parking)

Scale 1:10

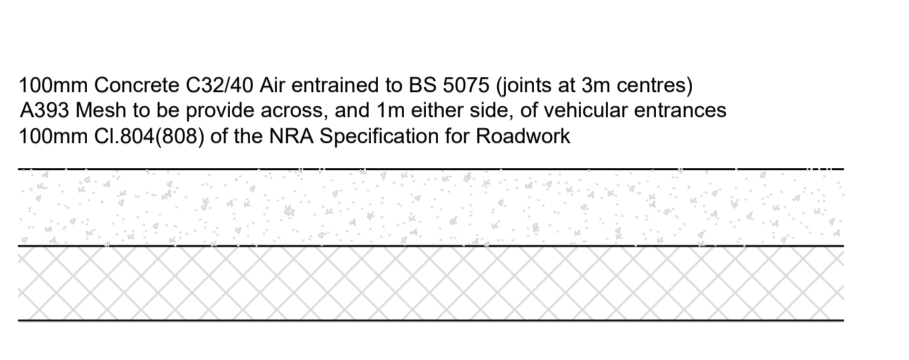

Concrete Path

Scale 1:10

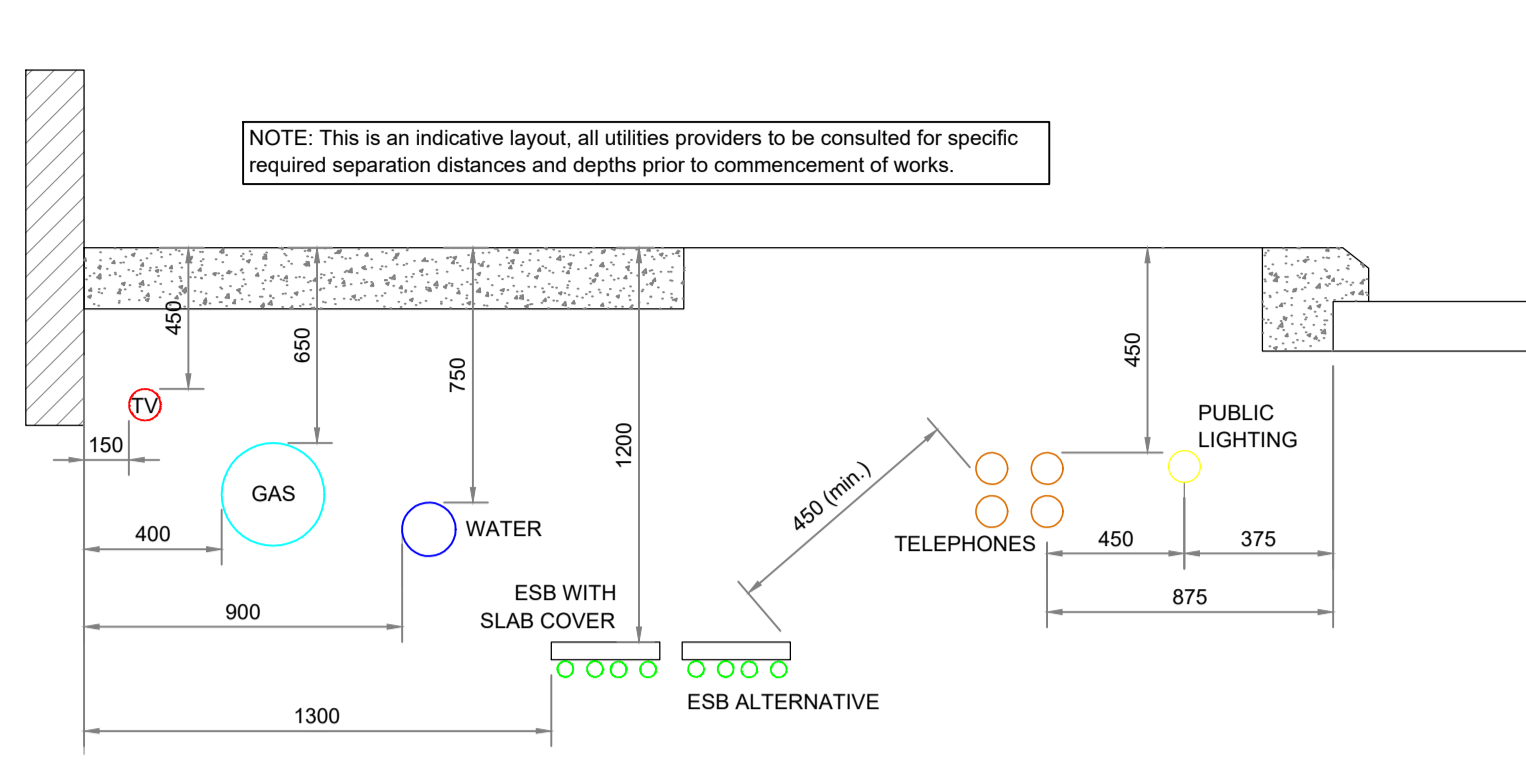

Typical Below Ground Services Layout Requirements

Scale 1:25

ROAD SPECIFICATION FOR ACCESS ROADS:

- All Granular fill Capping and Road Base to be certified for end use to the requirements of SR21 as above. Each layer shall be compacted with approved mechanical equipment in accordance with clause 612 of the NRA Specification. Generally the layers shall not exceed 150mm thick.
- Granular fill shall be obtained from an independently tested and approved quarry. The stone shall be certified as being not subject to swelling.
- CBR tests to be carried out at a maximum of 100 m c/c.
- Terram or similar approved may be required for low CBR values.
- All materials used in the Road Construction shall have a CE mark and shall be installed as per the manufactures specification.

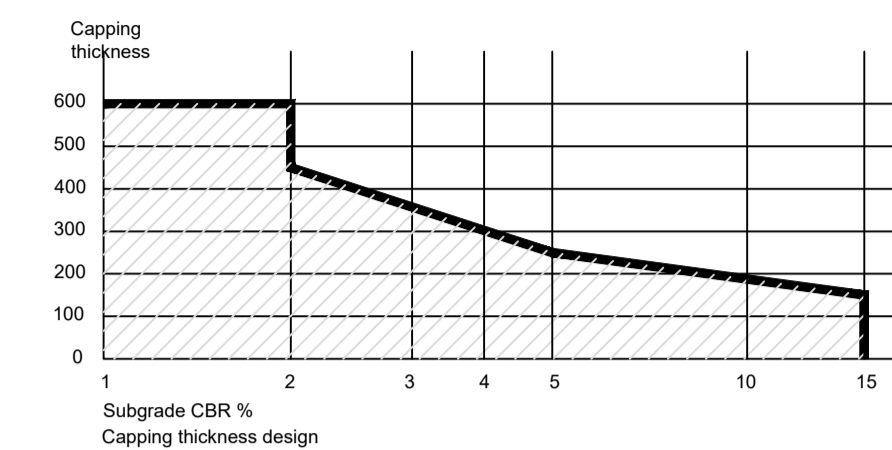

Capping thickness design

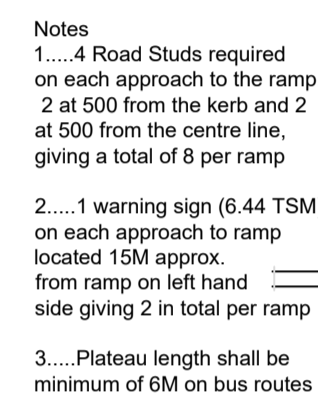

Typical Raised Table Warning Sign

Scale 1:50

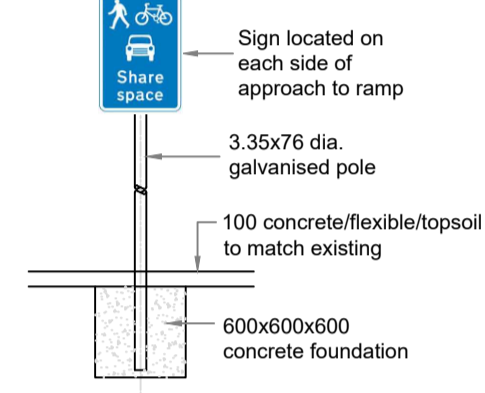

Typical Shared Surface Warning Sign

Scale 1:50

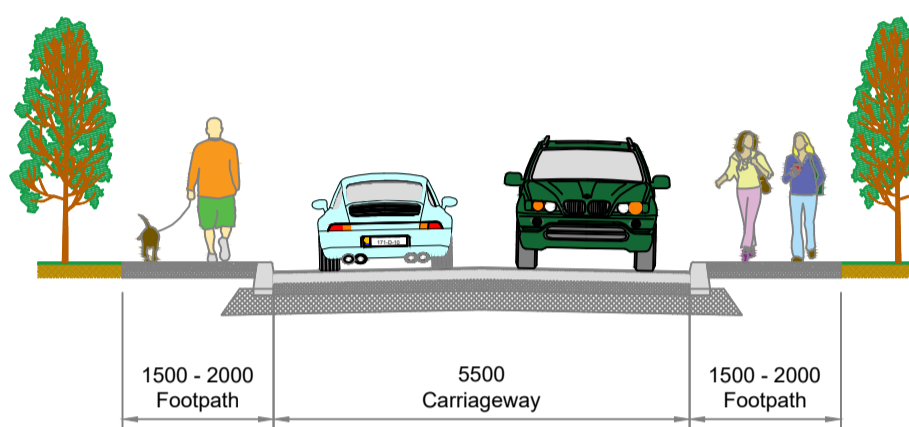

Typical Housing Estate - Road Cross Section

Scale 1:100

ROAD CONSTRUCTION:

- 40mm Polymer Modified Stone Mastic Asphalt Surface Course to CI.942 of the NRA Specification for Road Works.
- 60mm DBM Binder Course to CI.942 of the NRA Specification for Road Works.
- 60mm DBM Base Course to CI.942 of the NRA Specification for Road Works.
- 150mm (min) crushed stone sub base to be to clause 808 to the NRA Specification for Road Works laid and compacted to clause 802.
- 250mm (min) stone capping layer based on a CBR value of 5% to be confirmed on completion of CBR tests. Capping layer should be to Class 6F2 to the NRA Specification for Road Works. Capping must be increased for CBR values between 2% and 5% as per the Design table Figure 1. Capping layer of less than 250mm is not recommended irrespective of CBR value for values between 5% and 15%.

6F2 capping layer material shall be compacted with approved mechanical equipment in accordance with clause 612 of the NRA Specification. Generally the layers shall not exceed 150mm thick.

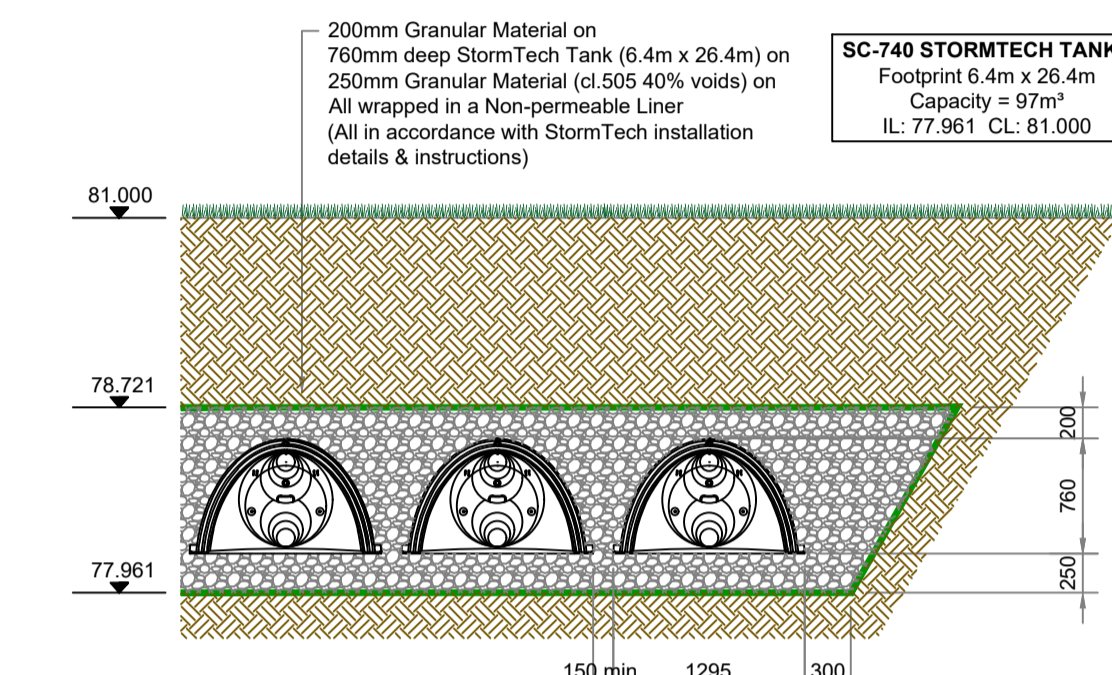

StormTech Attenuation - Typical End View

Scale 1:50

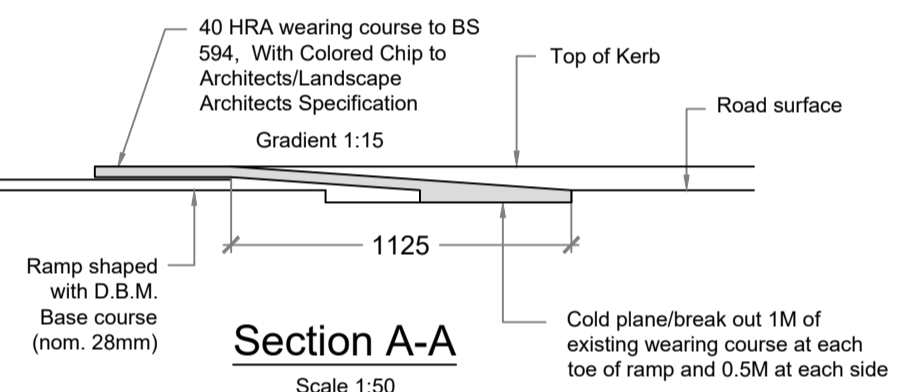

Section A-A

Scale 1:50

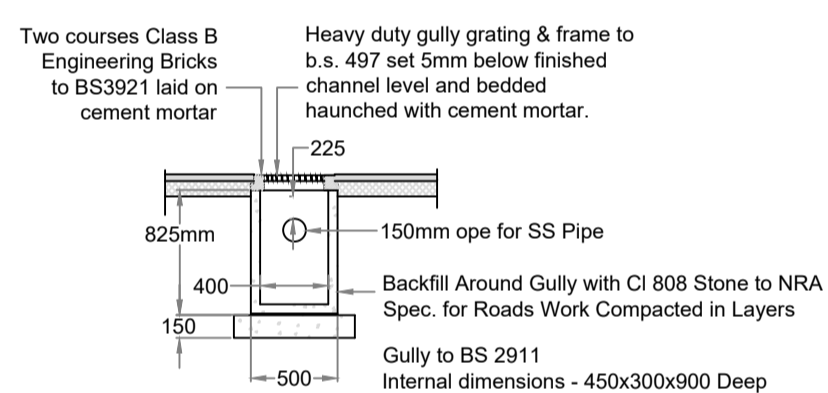

Precast Concrete Gully Pit - Section

Scale 1:50

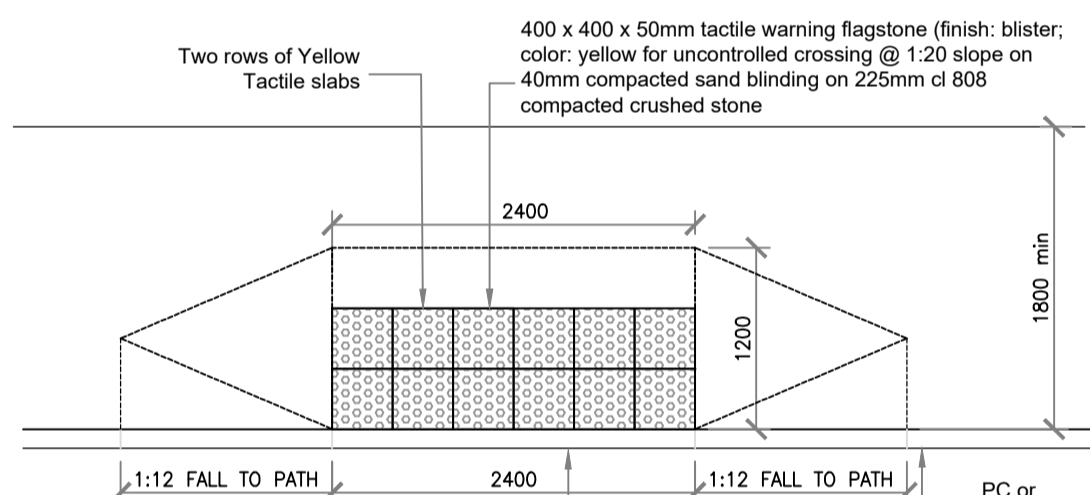

Type 2 - Perpendicular Pedestrian Crossing with Tactile Paving

Scale 1:50

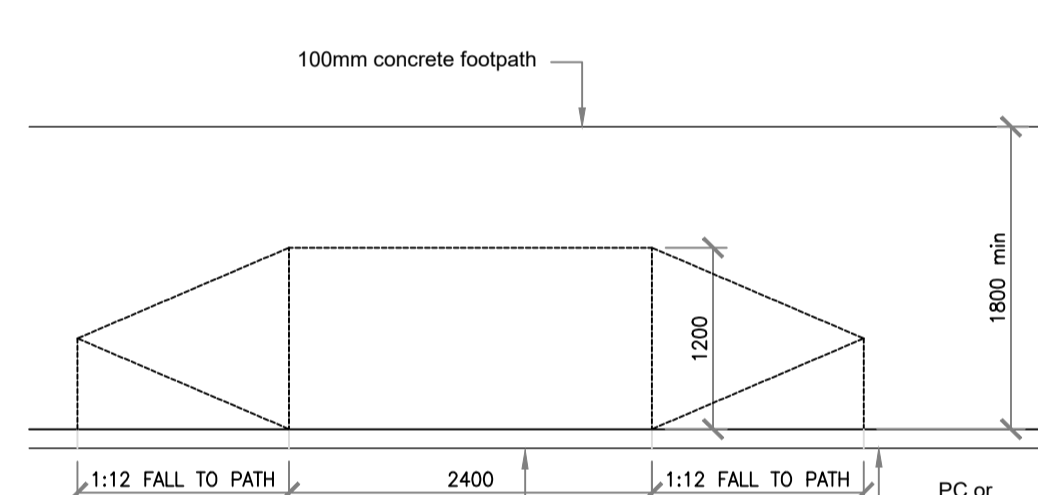

Type 1 - Perpendicular Pedestrian Crossing with no Tactile Paving

Scale 1:50

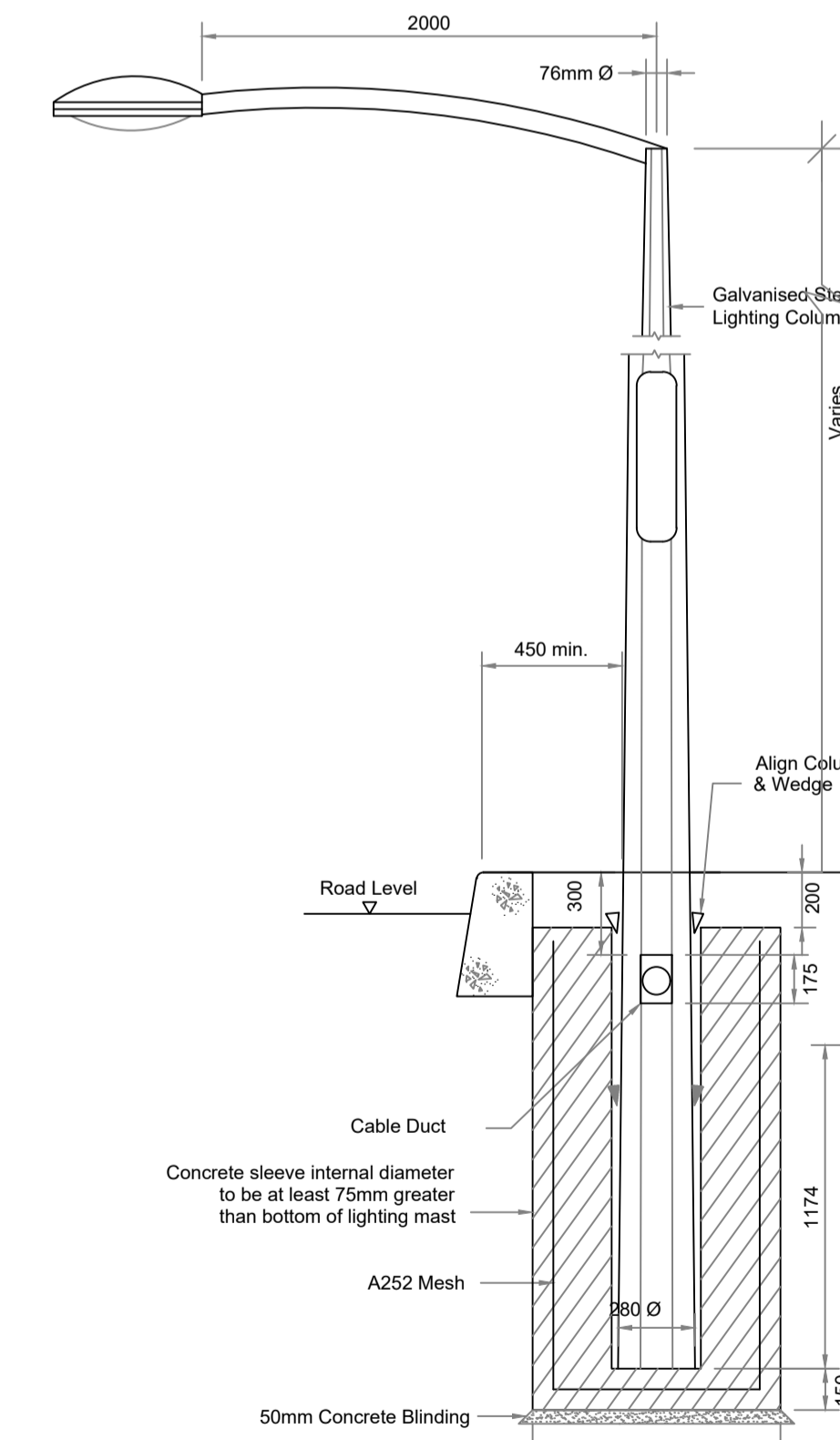

Elevation of Typical Lamp

Scale 1:25

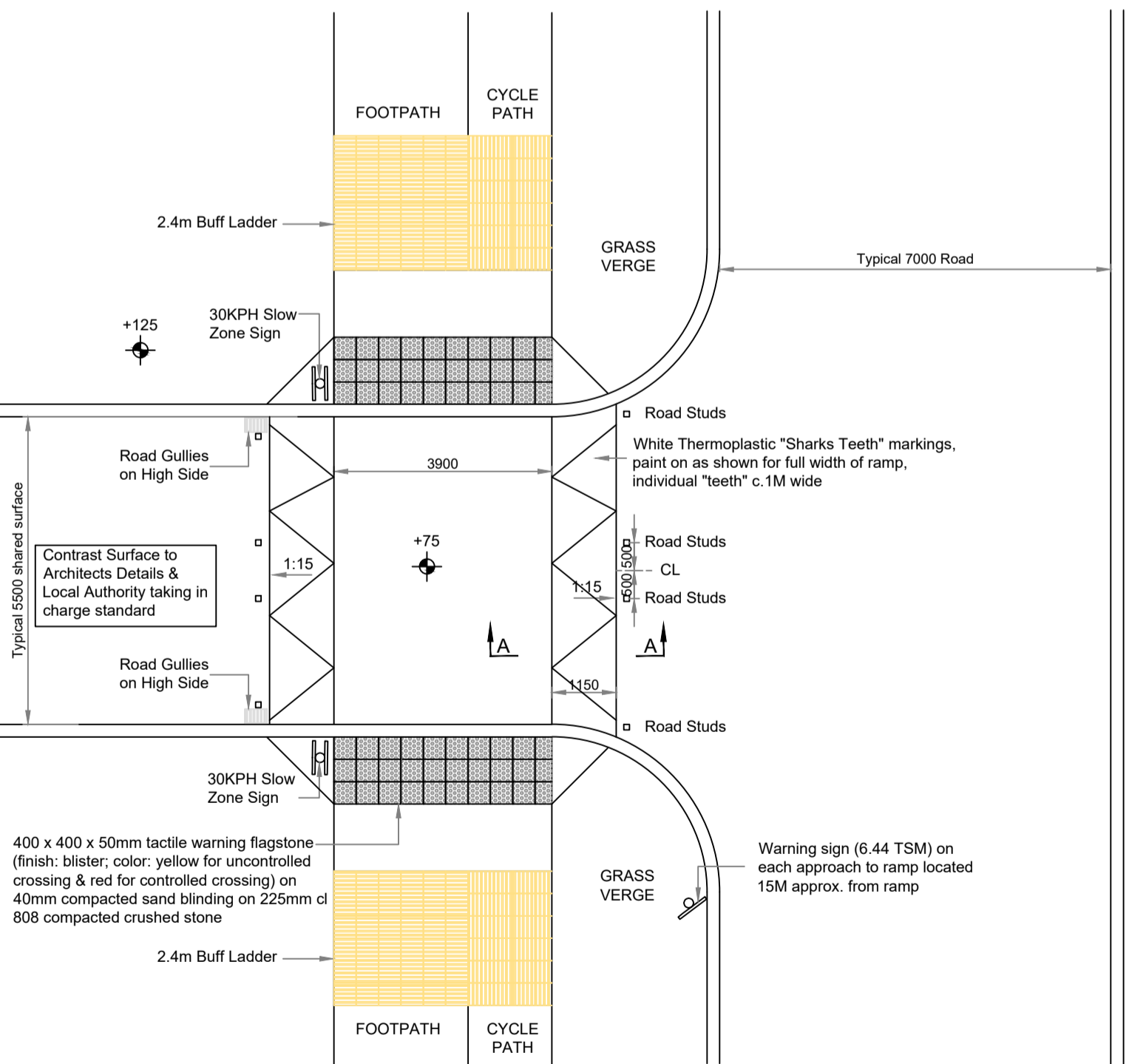

Plan on Raised Table at Junction

Scale 1:100

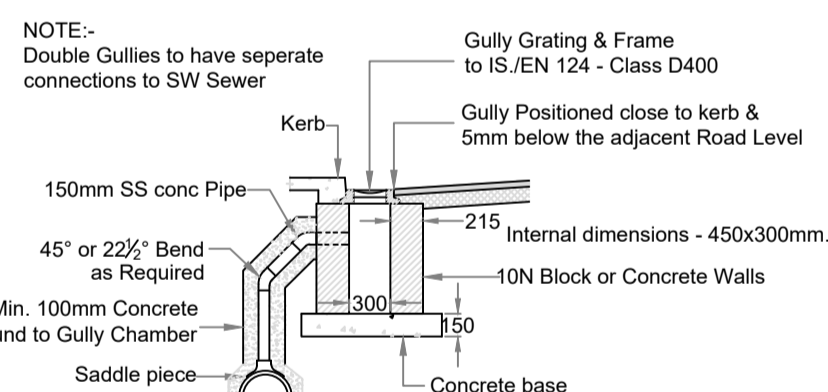

Gully Pit Connection to SW Sewer - Section

Scale 1:50

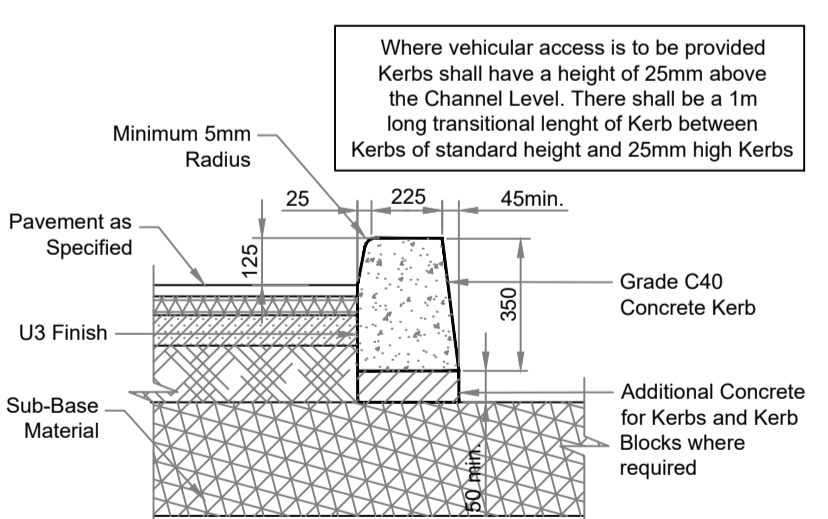

Typical Section through In-situ Slipform Concrete Kerb

Scale 1:20

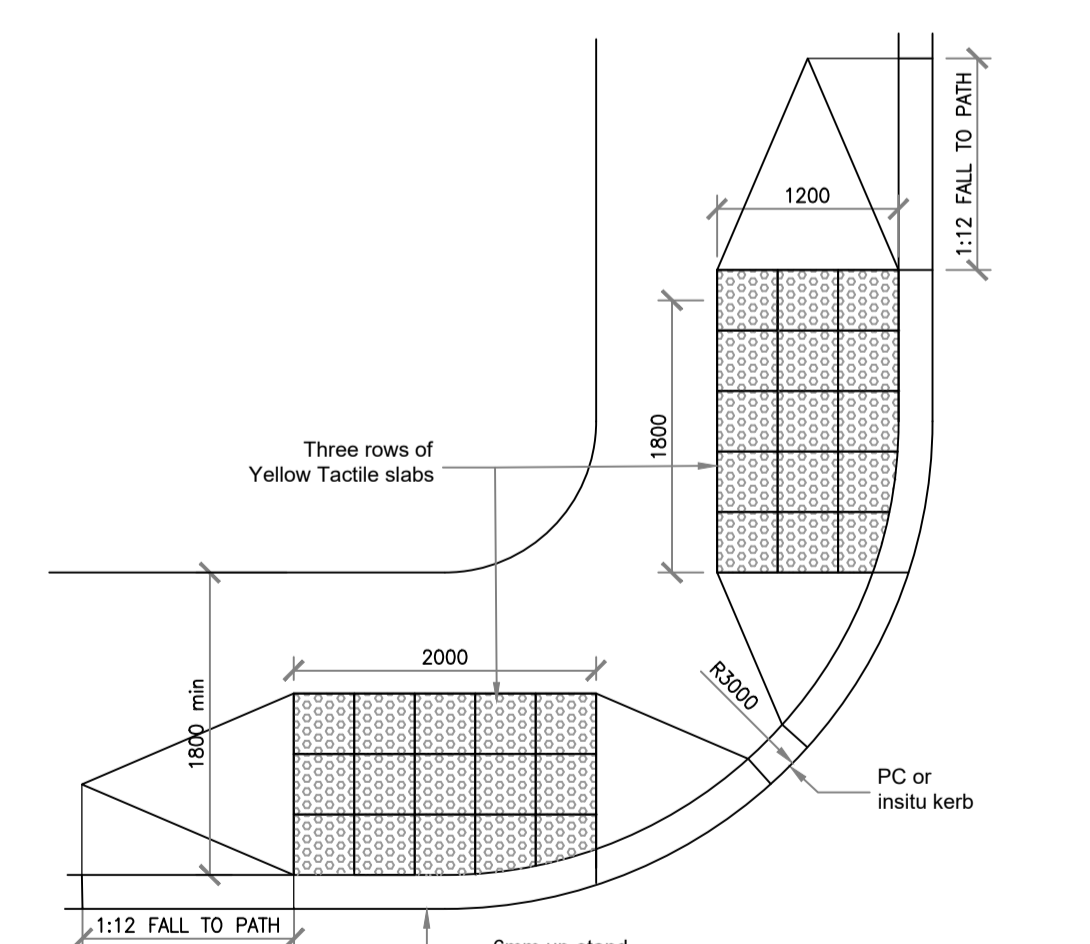

Type 2 - Junction Pedestrian Crossing with Tactile Paving

Scale 1:50

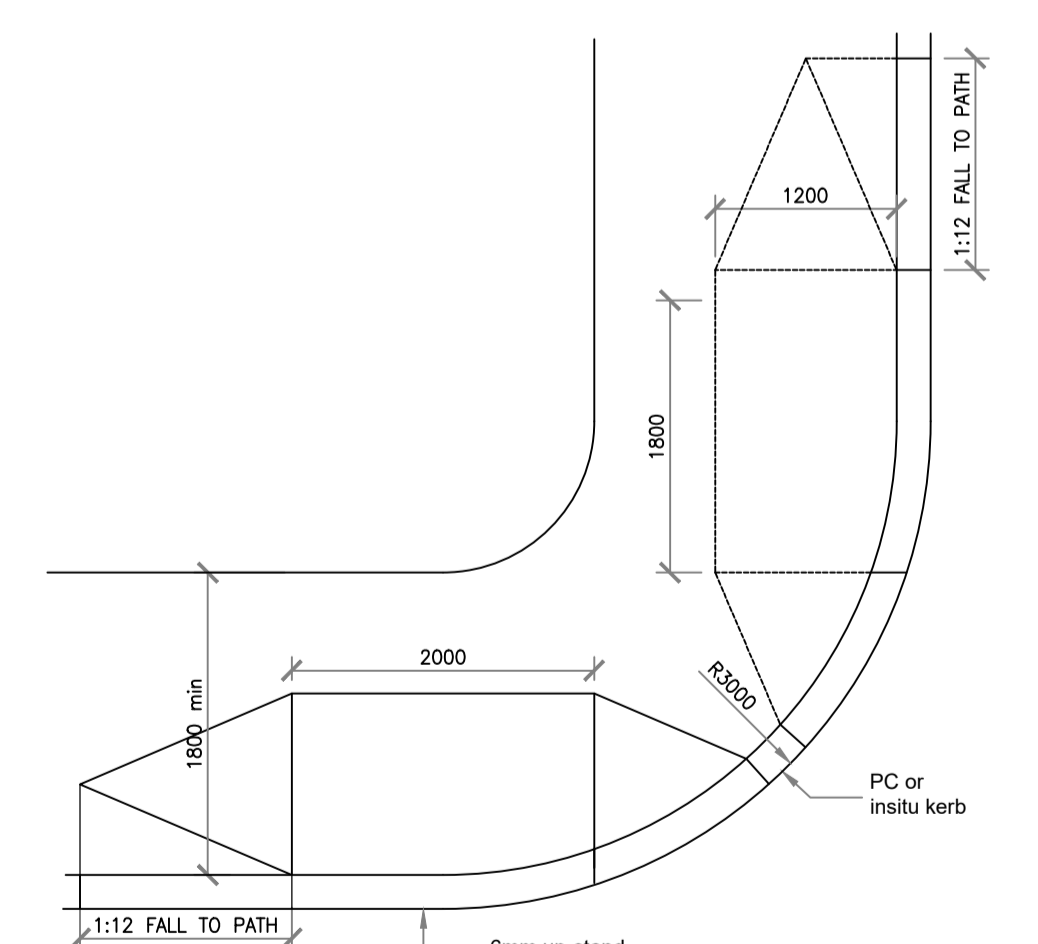

Type 1 - Junction Pedestrian Crossing with no Tactile Paving

Scale 1:50

Rev.	Date	Description	By

Project Title ST PATRICKS PARK RATHANGAN, CO. KILDARE			
Architect MCORM ARCHITECTS			
Date	By	Checked	Scale @ A1
OCT 2022	CB	NM	AS SHOWN

Drawing Title STANDARD ROAD AND SUDS & DRAINAGE DETAILS		
Drawing Status PLANNING		
Job No.	Drawing No.	Issue
1668	105	PO

POGa
CONSULTING ENGINEERS
STRUCTURAL - CIVIL

Unit C2, Nutgrove Office Park
Rathfarnham
Dublin 14
D14 CR20
Tel +353 (0)1 205 1101
www.poga.ie